

"aira" offers HIGH FLOW Diaphragm type solenoid valves, are specially engineered in the construction of Investment Cast CF8 / CF8M / CF3M body with S.S. Short & Electro Polished for multiple and long lasting operations.

Types :

1. Normally close - Energised to Open
2. Normally Open - Energised to Close

Application : Air, Water, Light Oil, Gas, Light Chemical

Size Range : 1/4" To 6" Screwed / Flanged / Triclover

"aira" solenoid valves are the best for the inflammable media / environment. The Flameproof / Explosion proof solenoid coils are available in such application.

Technical Specifications :

| | |
|-------------------|--|
| Body & Cover | ASTMA351 Gr. CF8 / CF8M / CF3M |
| Seals / Diaphragm | Nitrile / Neoprene (optional - silicon, viton & other) |
| Pressure Range | 0.5 to 10 bar |
| Temperature Range | -5° C to 85° C (On Request upto 120° C) |
| Coil Voltage | 12V, 24V, 48V, 110V, 230V, AC/DC |
| Coil Insulation | 'F' Class |
| Coil Rating | Continuous Rated |
| Ends | S/E, F/E 150#, T/C End |



Applications :

Textile Processing Machinery, Chemical Plants, Water Treatment, Sugar Machinery, Cement Machinery, Pumps, Irrigation, Combustion Equipment, Heat Exchanger, Air Dryer, Pollution Controls, Laundry Equipments and where dependable ON/OFF type control is required.

Solenoid Coil



(for General)



IP - 65 & IS:2147
(for Weather Proof)



Explosion & flame proof solenoid available on request.

(As per IS / IEC 60079-1 standard approved by Central Institute of Mining and Fuel Research (CIMFR))

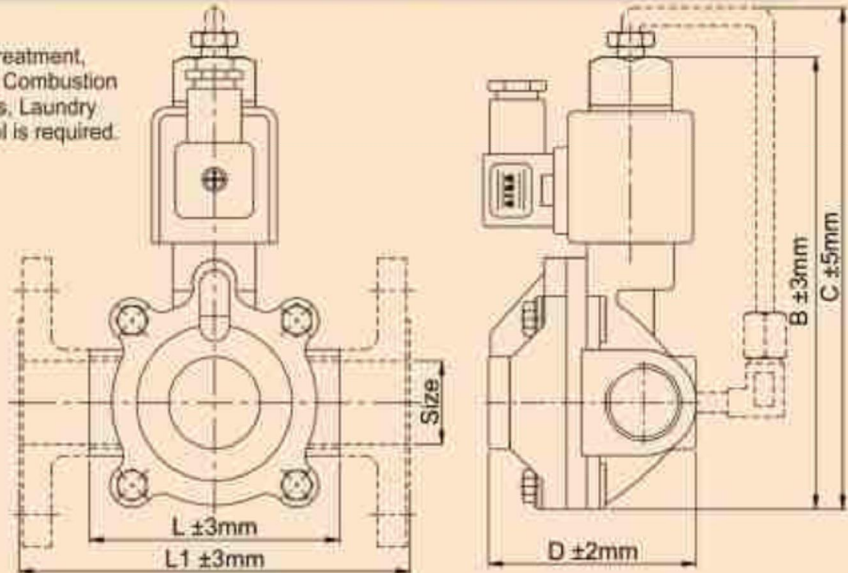

Dimensions :

(All Dimensions are in mm)

| Valve Model | Valve Size | | Flow Factor Kv m ³ /hr | L Screwed | L1 Flanged | B | C | D | Orifice mm | Weight (Approx) | |
|-------------|------------|--------|---|--------------|---------------|-------|-------|-------|---------------|-----------------|--------|
| | MM | Inch | | | | | | | | S/E | F/E |
| ISD - 6 | 6 | 1/4" | 2.5 | 66 | 130 | 126 | 170 | 55.5 | 19 | 0.800 | 1.200 |
| ISD - 10 | 10 | 3/8" | 2.5 | 66 | 130 | 126 | 170 | 55.5 | 19 | 0.800 | 1.200 |
| ISD - 15 | 15 | 1/2" | 3.5 | 66 | 130 | 126 | 170 | 55.5 | 19 | 0.800 | 1.200 |
| ISD - 20 | 20 | 3/4" | 5.0 | 80 | 150 | 133 | 175.5 | 85 | 19 | 1.100 | 1.600 |
| ISD - 25 | 25 | 1" | 11.0 | 95 | 160 | 150.5 | 195 | 81 | 24 | 1.400 | 2.150 |
| ISD - 32 | 32 | 1.1/4" | 13.0 | 119 | 180 | 160 | 207 | 98 | - | 2.000 | 3.300 |
| ISD - 40 | 40 | 1.1/2" | 20.0 | 119 | 200 | 160 | 207 | 98 | 34.50 | 2.000 | 3.300 |
| ISD - 50 | 50 | 2" | 38.0 | 137 | 230 | 181 | 229 | 116 | 45 | 2.900 | 5.000 |
| ISD - 65 | 65 | 2.1/2" | 67.6 | 172 | 290 | 197.5 | --- | 142.5 | 65 | 4.200 | 7.500 |
| ISD - 80 | 80 | 3" | 97.6 | 195 | 310 | 234 | --- | 158 | 72 | 5.900 | 10.050 |
| ISD - 100 | 100 | 4" | - | 300 | 350 | 281 | --- | 206 | 98 | 13.950 | 18.850 |
| ISD - 150 | 150 | 6" | - | - | - | - | - | - | - | - | - |

ON REQUEST