

■ **1/8 Solenoid Operated Directional Valves, DSG-01 Series**

- **WIDE RANGE OF MODELS--Choose the optimum valve to meet needs from a large selection available.**

The DSG-01 50 series solenoid operated directional valve comes with two basic models:

- **Standard type** ----- Useable at high pressure, high flow [315Kgf/cm<sup>2</sup>,63L/min.]
- **Shockless type** ----- which greatly reduces noise, which is a result of spool changeover and vibration in pipes.

The optimum valve for any system can be utilized since many spool types and various solenoids are all available, along with other optional functions.

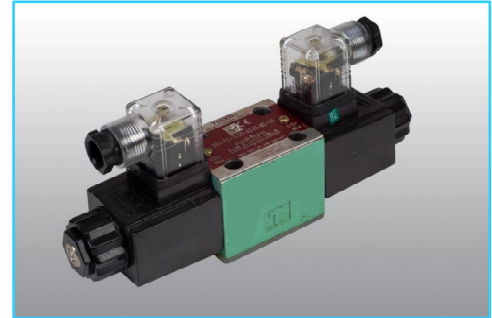

■ **Specification**

Valve Type	Model Numbers	Max. Flow* L/min	Max. Operating Pressure Kgf/cm <sup>2</sup>	Max. T-Line Back Pressure Kgf/cm <sup>2</sup>	Max. Changeover Frequency Cycles/Min.	Mass Kg
Standard Type	DSG-01-3C※-※-50	63	315 {Spool Type 60 Only 250}	160	300 {R Type Sol. Only 120}	2.2
	DSG-01-2D2※-※-50					1.6
	DSG-01-2B※-※-50					1.6
Shockless Type	S-DSG-01-3C※-※-50	40	160	160	120	2.2
	S-DSG-01-2B2※-※-50					1.6

\* Maximum flow indicates a ceiling flow. As the ceiling flow depends on the type of spool and operating condition, refer to the list of standard models & maximum flow on page 3 & 4 for details.

■ **Sub-Plates**

Sub-plate Model Numbers	Thread Size	Approx. Mass Kg.
DSGM-01-3080	1/8 BSP.F	0.8
DSGM-01X-3080	1/4 BSP.F	0.8

\* Sub-plates are available. Specify the sub-plate model number from the table above. When sub-plates are not used, the mounting surface should have a good machined finish.

■ **Mounting Bolts**

Four socket head cap screws as in the table below are included.

Soc. Hd. Cap Screw	Qty.	Mounting Bolt Kit Number
M5 x 45 Lg.	4	BKDGS-01-50

**Solenoid Ratings**

Valve Type	Electric source	Coil Type	Frequency (Hz)	Voltage (V)		Current & Power at Rated Voltage					
				Source Rating	Serviceable Range	Inrush (A) *2	Holding (A)	Power (W)			
Standard Type	*1 AC	A100	50	100	80 - 110	2.38	0.46	---			
			60	100	90 - 120	2.12	0.32				
				110		2.33	0.39				
		A120	50	120	96 - 132	1.98	0.38				
			60		108 - 144	1.77	0.27				
		A200	50	200	160 - 220	1.19	0.23				
			60		200	180 - 240	1.06		0.16		
					220		1.17		0.19		
		A240	50	240	192 - 264	0.99	0.19				
			60		216 - 288	0.89	0.13				
		Shockless Type	DC (K Series)	-----	-----	12	10.8 - 13.2		-----	2.2	26
						24	21.6 - 26.4			1.1	
48	43.2 - 52.8					0.54					
100	90 - 110					0.27					
110	99 - 121					0.24					
200	180 - 220					0.13					
220	198 - 242					0.12					
AC→DC Rectified	50/60					-----	50/60	100		90 - 110	
		110	99 - 121	0.26							
		200	180 - 220	0.14							
		220	198 - 242	0.13							

\*1 AC solenoid is not available in shockless type.

R type models with built-in current rectifier is recommended for shockless operation with AC power.

\*2 Inrush current in the above table show rms values at maximum stroke.

**Model Number Designation**

F	S-	DSG	- 01	- 2	B	2	A	- A 100	-C	- N	50	- L	
Special Seals	Type	Series Number	Valve Size	Number of Valve Positions	Spool - Spring Arrangement	Spool Type	Special Two Position Valve [Omit if not required]	Coil Type	Manual Override	Electrical Conduit Connection	Design Number	Models with Alternate offset Solenoid [Omit if not required]	
F: Special Seals for Phosphate Ester Type Fluids (Omit if not required)	None: Standard Type	DSG: Solenoid Operated Directional Valve	01	3: Three Positions	C: Spring Centered	2, 3 4, 40 5, 60 7, 8 9, 10 11, 12	--	AC: A 100 A 120 A 200 A 240	None: Manual Override Pin  C: Push Button and Lock Nut (Option)	None: Terminal Box Type  N: With Plug-in Connector (DIN)  N1: With Plug-in Connector with Indicator Light (Option)	50	--	
					D: No-Spring Detented	2, 3 7, 8	A <sup>1</sup>	DC: D 12, D 24, D 48, D 100, D 110, D 200, D 220				L	
	S: Shock-Less Type			3: Three Positions	C: Spring Centered	2 4, 40	--	DC: D 12, D 24, D 48, D 100, D 110, D 200, D 220				R: (AC→DC) R 100, R110 R 200, R220	L
					N: No-Spring	2							
				2: Two Positions	B: Spring Offset	2						L	

\* 1 Another spool types for special 2-position valves are available in addition to spool type 2,3,7 and 8.

\* 2 Coil type "R" is not available for plug-in connector with indicator light type "N1".

\* 3 Design numbers subject to change. But installation dimensions remain as shown for deign number 50 through 59.

Note: Models with Rubber dust Cap at manual push pin are also available. Consult Yuken for details.

List of Standard Models and Maximum Flow

Model with AC Solenoids : DSG-01-\*\*\*-A\*

No. of Valve Positions Spool-Spring Arrangements	Model Numbers	Graphic Symbols	Max. Flow L/min														
			50 Kg <sub>f</sub> /cm <sup>2</sup>	100 Kg <sub>f</sub> /cm <sup>2</sup>	160 Kg <sub>f</sub> /cm <sup>2</sup>	250 Kg <sub>f</sub> /cm <sup>2</sup>	315 Kg <sub>f</sub> /cm <sup>2</sup>	50 Kg <sub>f</sub> /cm <sup>2</sup>	100 Kg <sub>f</sub> /cm <sup>2</sup>	160 Kg <sub>f</sub> /cm <sup>2</sup>	250 Kg <sub>f</sub> /cm <sup>2</sup>	315 Kg <sub>f</sub> /cm <sup>2</sup>	50 Kg <sub>f</sub> /cm <sup>2</sup>	100 Kg <sub>f</sub> /cm <sup>2</sup>	160 Kg <sub>f</sub> /cm <sup>2</sup>	250 Kg <sub>f</sub> /cm <sup>2</sup>	315 Kg <sub>f</sub> /cm <sup>2</sup>
Three Positions Spring Centered	DSG-01-3C2		63	63	63	63	63	63 (30) 45 (25)	63 (23) 33 (18)	63 (15) 20 (10)	50 (10) 13 (5)	40 (10) 13 (5)	63 (30) 45 (25)	63 (23) 33 (18)	63 (15) 20 (10)	50 (10) 13 (5)	40 (10) 13 (5)
	DSG-01-3C3		63	63	63	63	63	63	63	63	63	63	63	63	63	63	63
	DSG-01-3C4		63	63	63	63	63 (48) 63 (43)	63 (25) 58 (20)	63 (23) 48 (18)	63 (20) 35 (15)	63 (13) 20 (8)	55 (10) 13 (5)	63 (25) 58 (20)	63 (23) 48 (18)	63 (20) 35 (15)	63 (13) 20 (8)	55 (10) 13 (5)
	DSG-01-3C40		63	63	63	63	63	63 (30) 45 (25)	63 (23) 33 (18)	63 (15) 20 (10)	50 (10) 13 (5)	40 (10) 13 (5)	63 (30) 45 (25)	63 (23) 33 (18)	63 (15) 20 (10)	50 (10) 13 (5)	40 (10) 13 (5)
	DSG-01-3C5*		45	43	40	40	--	45	43	40	40	--	45	43	40	40	--
	DSG-01-3C60*		45	43	40	40	--	45	43	40	40	--	45	43	40	40	--
	DSG-01-3C7		63	63	63	63	63	63	63	63	63	63	63	63	63	63	63
	DSG-01-3C8		--	--	--	--	--	63 (25) 63 (20)	63 (25) 38 (20)	63 (25) 28 (20)	63 (15) 20 (10)	63 (10) 15 (5)	63 (25) 63 (20)	63 (25) 38 (20)	63 (25) 28 (20)	63 (13) 20 (10)	63 (10) 15 (5)
	DSG-01-3C9		63	63	63	63	63	28	20	15	10	10	28	20	15	10	10
	DSG-01-3C10		63	63	63	63	63	63 (38) 63 (33)	63 (30) 45 (25)	63 (25) 30 (20)	63 (15) 20 (10)	63 (13) 15 (8)	63 (38) 63 (33)	63 (30) 45 (25)	63 (25) 30 (20)	63 (15) 20 (10)	63 (13) 15 (8)
	DSG-01-3C11		63	63	63	63	63	30	23	20	13	10	63 (58) 63 (50)	63 (45) 63 (50)	63 (45) 63 (50)	63 (45) 63 (50)	63 (45) 63 (50)
	DSG-01-3C12		63	63	63	63	63	63 (30) 63 (25)	63 (28) 35 (23)	63 (23) 25 (18)	63 (18) 18 (13)	63 (15) 15 (10)	63 (30) 63 (25)	63 (28) 35 (23)	63 (23) 25 (18)	63 (18) 18 (13)	63 (15) 15 (10)
Two Positions No Spring Detented	DSG-01-2D2		63	63	63	63	63	45	45	45	45 (35) 40 (30)	45 (25) 30 (20)	45	45	45	45 (35) 40 (30)	45 (25) 30 (20)
	DSG-01-2D3		63	63	63	63	63	45	45	45	45 (35) 40 (30)	45 (25) 30 (20)	45	45	45	45 (35) 40 (30)	45 (25) 30 (20)
	DSG-01-2D7		63	63	63	63	63	45	45	45	45 (35) 40 (30)	45 (25) 30 (20)	45	45	45	45 (35) 40 (30)	45 (25) 30 (20)
	DSG-01-2D8		--	--	--	--	--	40 (30) 35 (30)	40 (30) 35 (30)	40 (30) 35 (30)	35 (30) 30 (25)	35 (25) 25 (20)	40 (30) 35 (30)	40 (30) 35 (30)	40 (30) 35 (30)	35 (30) 30 (25)	35 (25) 25 (20)
	DSG-01-2B2		63	63	63	63	63	20	20	20	20	20	63	63 (55) 63 (50)	63 (50) 63 (45)	63 (50) 63 (45)	63 (45) 60 (40)
	DSG-01-2B3		63	63 63 (60)	63 63 (60)	63 63 (60)	63 63 (60)	50	50	50	50	50	63 63 (55)	63 63 (55)	63 63 (55)	63 63 (55)	63 63 (55)
	DSG-01-2B8		--	--	--	--	--	25	13	10	10	10	63 (28) 63 (23)	63 (25) 35 (20)	63 (20) 23 (15)	63 (13) 15 (8)	50 (10) 10 (5)

Note :

- 1 Maximum Flow rates and applied current.
  - The single column describes maximum flow rates regardless of whether AC solenoid 50 Hz or 60 Hz as long as it is within serviceable voltage range.
  - Maximum flow rates at 50 Hz solenoid with serviceable voltage range, refer to the figures in the upper column and 60 Hz solenoid as long as it is within serviceable voltage range. Refer to the figures in the latter column.
- Where two figures are shown in the same column , the figure outside ( ) is at rated voltage and inside ( ) is at the minimum permissible solenoid voltage.

(Example)

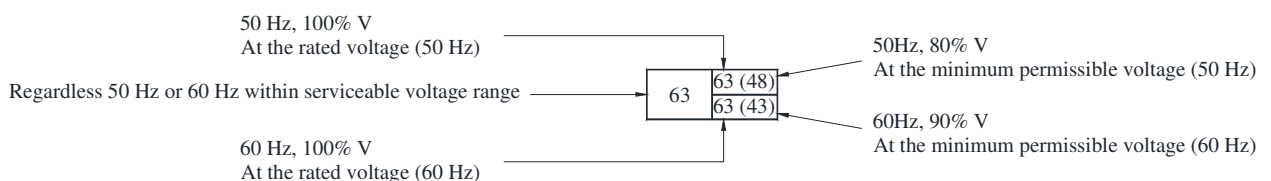

2 For the maximum flow between P and T of those valves marked \* , refer to page 5.

**List of Standard Models and Maximum Flow**

● **Model with DC or R Type Solenoids : DSG-01-※※※-D※/R※**

No. of Valve Positions Spool-Spring Arrangements	Model Numbers	Graphic Symbols	Max. Flow L/min															
			50 Kgf/cm <sup>2</sup>	100 Kgf/cm <sup>2</sup>	160 Kgf/cm <sup>2</sup>	250 Kgf/cm <sup>2</sup>	315 Kgf/cm <sup>2</sup>	50 Kgf/cm <sup>2</sup>	100 Kgf/cm <sup>2</sup>	160 Kgf/cm <sup>2</sup>	250 Kgf/cm <sup>2</sup>	315 Kgf/cm <sup>2</sup>	50 Kgf/cm <sup>2</sup>	100 Kgf/cm <sup>2</sup>	160 Kgf/cm <sup>2</sup>	250 Kgf/cm <sup>2</sup>	315 Kgf/cm <sup>2</sup>	
Three Positions Spring Centered	DSG-01-3C2		63	63	63	63	63	45	30	20	15	13	45	30	20	15	13	
	DSG-01-3C3		63	63	63	63	63	63	63	63	63	63	63	63	63	63	63	
	DSG-01-3C4		63	63	63	63	35	63	45	35	30	28	63	45	35	30	28	
	DSG-01-3C40		63	63	63	63	63	50	30	23	15	13	50	30	23	15	13	
	DSG-01-3C5*		45	43	40	40	--	45	43	40	40	--	45	43	40	40	--	
	DSG-01-3C60*		45	43	40	40	--	45	43	40	40	--	45	43	40	40	--	
	DSG-01-3C7		63	63	63	63	63	63	63	63	63	63	63	63	63	63	63	
	DSG-01-3C8		--	--	--	--	--	63	50	30	20	15	63	50	30	20	15	
	DSG-01-3C9		63	63	63	63	63	25	20	15	10	10	25	20	15	10	10	
	DSG-01-3C10		63	63	63	63	45	63	55	40	28	20	63	55	40	28	20	
	DSG-01-3C11		63	63	63	63	63	30	23	20	13	10	63	58	55	55	55	
	DSG-01-3C12		63	63	63	63	38	63	60	40	25	20	63	60	40	25	20	
Two Positions No Spring Detented	DSG-01-2D2		63	63	63	63	63	45	45	45	40	30	45	45	45	40	30	
	DSG-01-2D3		63	63	63	63	63	45	45	45	40	30	45	45	45	40	30	
	DSG-01-2D7		63	63	63	63	63	45	45	45	40	30	45	45	45	40	30	
	DSG-01-2D8		--	--	--	--	--	35	35	35	30	25	35	35	35	30	25	
	Two Positions Spring Offset	DSG-01-2B2		63	63	63	63	63	20	18	18	18	18	63	58	40	30	30
		DSG-01-2B3		38	38	38	38	38	48	48	45	45	40	63	63	63	63	63
		DSG-01-2B8		28	28	28	28	28	45	45	40	40	38	63	60	60	60	60
				--	--	--	--	--	25	13	10	8	8	63	48	28	15	15

Note:

- Maximum Flow Rates and applied current.
  - The single column describes maximum flow rates regardless of voltage as long as it is within the serviceable voltage range.
  - Where two figures are shown in the same column, the upper is at rated voltage and the latter is at the minimum permissible solenoid voltage.

(Example)

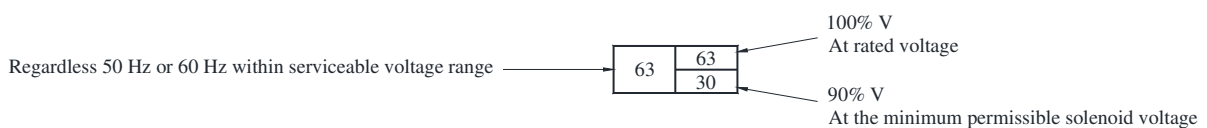

2 For the maximum flow between P and T of those valves marked \*, refer to page 5.

**Maximum Flow of Centre By-Pass**

In spool type 5 and 60, P→T (Center By-Pass) flow rates are limited as shown in the column below. Described maximum flow rates are regardless voltage within serviceable voltage range.

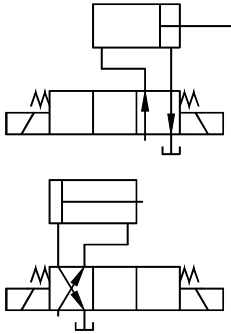

Model Numbers	Graphic Symbols	Max. Flow L/min.			
		50 Kg/cm <sup>2</sup>	100 Kg/cm <sup>2</sup>	160 Kg/cm <sup>2</sup>	250 Kg/cm <sup>2</sup>
DSG-01-3C5-A※/D※/R※		45	43	40	30
DSG-01-3C60-A※/D※/R※		45	43	40	30

**List of Spool Function of Shock-Less Type**

- Model with DC or R Type Solenoids : S-DSG-01-※※※-D※/R※

No. Of Valve Positions	Spool Spring Arrangement	Model Numbers	Graphic Symbols	Max. Flow L/min.								
				P → A → B → T B → A			P → A [Port "B" Blocked]			P → B [Port "A" Blocked]		
				100	160	250	100	160	250	100	160	250
Three Positions	Spring Centered	S-DSG-01-3C2		63	63	40	40	32	25	40	32	25
		S-DSG-01-3C4		60	50	40	40	32	16	40	32	16
Two Positions	Spring Offset	S-DSG-01-2B2		50	45	45	30	30	30	60	40	40
				45	40	40						

Note:

- Maximum Flow Rates and applied current.
- The single column describes maximum flow rates regardless voltage within serviceable voltage range.
  - Where two figures are shown in the same column, the upper is at rated voltage and the latter is at the minimum permissible solenoid voltage.

(Example)

Regardless voltage within serviceable range

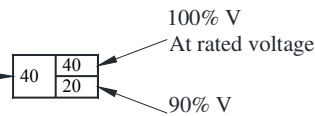

At the minimum permissible solenoid voltage

**Options**

Model With Push Button & Lock Nut : (S-) DSG-01-※※※-※C-(<sup>N</sup>/<sub>N1</sub>)-50

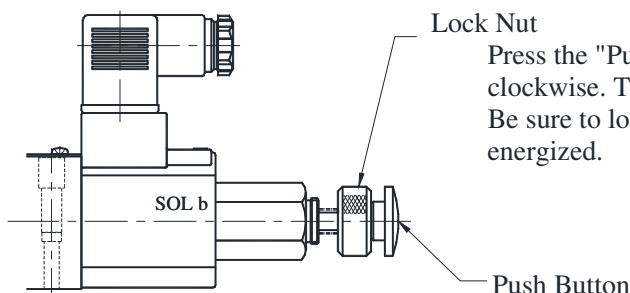

Press the "Push Button" then turn "Lock Nut" clockwise. The position of the "Push Button" is held. Be sure to loosen "Lock Nut" fully before solenoid is energized.

**Typical Changeover Time**

Changeover time varies according to oil Viscosity, spool type and hydraulic circuit

[Test Conditions]

Pressure : 160 Kg/cm<sup>2</sup>

Flow Rate: 31.5 L/min

Viscosity: 35cSt

Voltage : 100% V

(After coil temperature rise and saturates)

**Standard Type**

(Without Shockless Function)

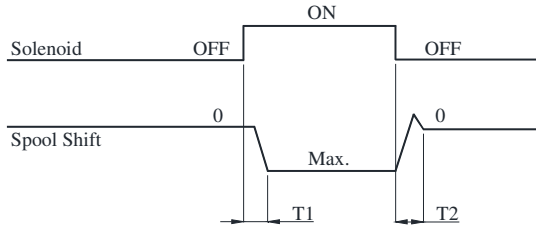

**[Result of Measurement]**

Type	Model Numbers	Changeover Time ms	
		T1	T2
Standard Type	DSG-01-3C2-A※	15	23
	DSG-01-3C2-D※	48	19
	DSG-01-3C2-R※	50	100

**Shockless Type**

[Test Circuit an Conditions]

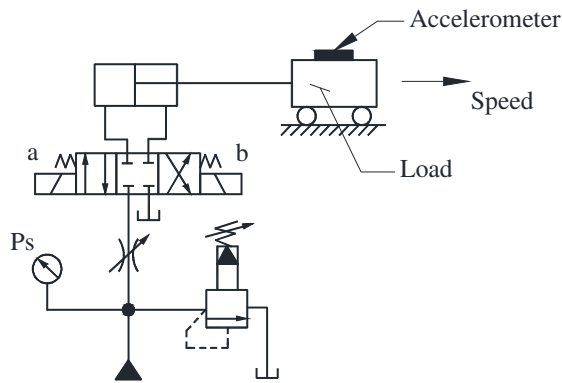

Setting Pressure (Ps): 70 Kg/cm<sup>2</sup>

Speed :8m/min

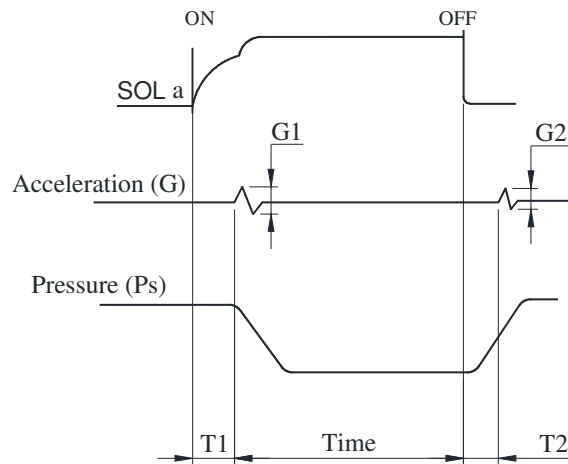

**[Result of Measurement]**

Type	Model Numbers	Time ms		Acceleration G	
		T1	T2	G1	G2
Shockless Type	S-DSG-03-3C2-D※	70	30	1.2	0.7
Standard Type	DSG-03-3C2-D※	35	25	1.8	1.5

**Spring Offset Valves with Alternate Solenoid**

Through our standard spring offset models use solenoid “b”, alternate models using solenoid “a” are also available. The graphic symbols are expressed below.

For Models 2 B※ A and 2B※ B, refer to table below.

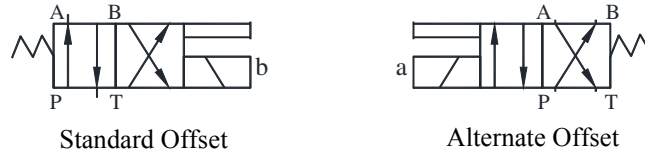

**Valves with Center position and One Offset Position (Special Two Position Valve)**

In addition to the standard two position valves shown on the table on page 3 and 4 two kinds of valves are available with center position and either one of two offset positions.

Standard and alternate offset types use solenoid “b” and solenoid “a” respectively.

**(Example) In case of spool Type “2”**

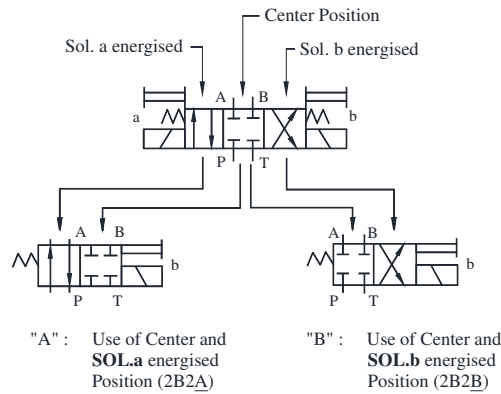

Model Number	Graphic Symbol		Model Number	Graphic Symbol		Model Number	Graphic Symbol
	Standard Offset Type	Alternate Offset Type		Standard Offset Type	Alternate Offset Type		Standard Offset Type
DSG-01-2B※ A			DSG-01-2B※ B			DSG-01-2D※ A	
DSG-01-2B2A			DSG-01-2B2B			DSG-01-2D2A	
DSG-01-2B3A			DSG-01-2B3B			DSG-01-2D3A	
DSG-01-2B4A			DSG-01-2B4B			DSG-01-2D4A	
DSG-01-2B40A			DSG-01-2B40B			DSG-01-2D40A	
DSG-01-2B5A			DSG-01-2B5B			DSG-01-2D5A	
DSG-01-2B60A			DSG-01-2B60B			DSG-01-2D7A	
DSG-01-2B7A			DSG-01-2B7B			DSG-01-2D9A	
DSG-01-2B8A			DSG-01-2B8B			DSG-01-2D10A	
DSG-01-2B9A			DSG-01-2B9B			DSG-01-2D11A	
DSG-01-2B10A			DSG-01-2B10B			DSG-01-2D12A	
DSG-01-2B11A			DSG-01-2B11B				
DSG-01-2B12A			DSG-01-2B12B				

**Pressure Drop**

Pressure drop based on viscosity cSt and specific gravity of 0.850.

● **Standard Type : DSG-01**

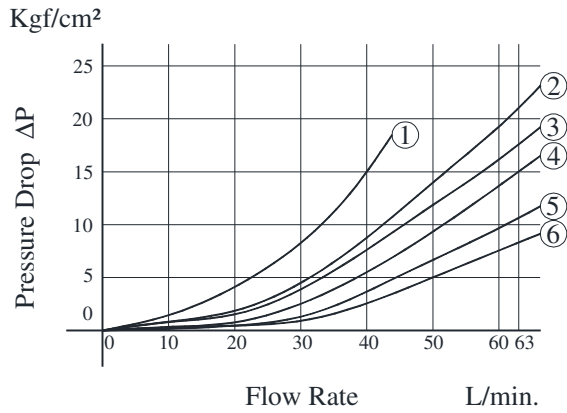

Model Numbers	Pressure Drop Curve Number				
	P→A	B→T	P→B	A→T	P→T
DSG-01-3C2	⑤	⑤	⑤	⑤	—
DSG-01-3C3	⑥	⑥	⑥	⑥	④
DSG-01-3C4	⑤	⑥	⑤	⑥	—
DSG-01-3C40	⑤	⑤	⑤	⑤	—
DSG-01-3C5	①	①	①	①	④
DSG-01-3C60	①	①	①	①	④
DSG-01-3C7	⑤	⑤	⑤	⑤	—
DSG-01-3C8	⑤	—	⑤	—	—
DSG-01-3C9	⑥	⑤	⑥	⑤	—
DSG-01-3C10	⑤	⑥	⑤	⑤	—
DSG-01-3C11	⑥	⑤	⑤	⑤	—
DSG-01-3C12	⑤	⑤	⑤	⑥	—
DSG-01-2D2	⑤	②	⑤	②	—
DSG-01-2D3	⑤	③	⑤	③	—
DSG-01-2D7	⑤	③	⑤	③	—
DSG-01-2D8	⑤	—	⑤	—	—
DSG-01-2B2	②	②	⑤	⑤	—
DSG-01-2B3	③	③	⑤	⑥	—
DSG-01-2B8	⑤	—	⑤	—	—
DSG-01-2N2	⑤	②	⑤	②	—
DSG-01-2N3	⑤	③	⑤	③	—
DSG-01-2N7	⑤	③	⑤	③	—
DSG-01-2N8	⑤	—	⑤	—	—

● **Shock-Less Type : S-DSG-01**

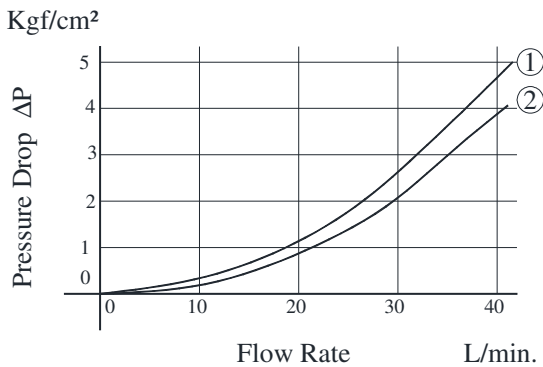

Model Numbers	Pressure Drop Curve Number			
	P→A	B→T	P→B	A→T
S-DSG-01-3C2	①	①	①	①
S-DSG-01-3C4	①	②	①	②
S-DSG-01-3C40	①	②	①	②
S-DSG-01-2N2	①	①	①	①
S-DSG-01-2B2	①	①	①	①

● For any other viscosity, multiply the factors in the table below.

Viscosity	cSt (mm <sup>2</sup> /s)	15	20	30	40	50	60	70	80	90	100
Factor		0.81	0.87	0.96	1.03	1.09	1.14	1.19	1.23	1.27	1.30

● For any other specific gravity (G'), the pressure drop (ΔP') can be obtained from the formula below.

$$\Delta P' = P(G'/0.850)$$



**TERMINAL BOX TYPE**

**DIMENSIONS IN MILLIMETRES**

**Models With AC Solenoid**

- Double Solenoid: Spring Centred & No-Spring Detented
- **DSG-01-3C<sup>※</sup>-A<sup>※</sup>-50**  
**2D2**

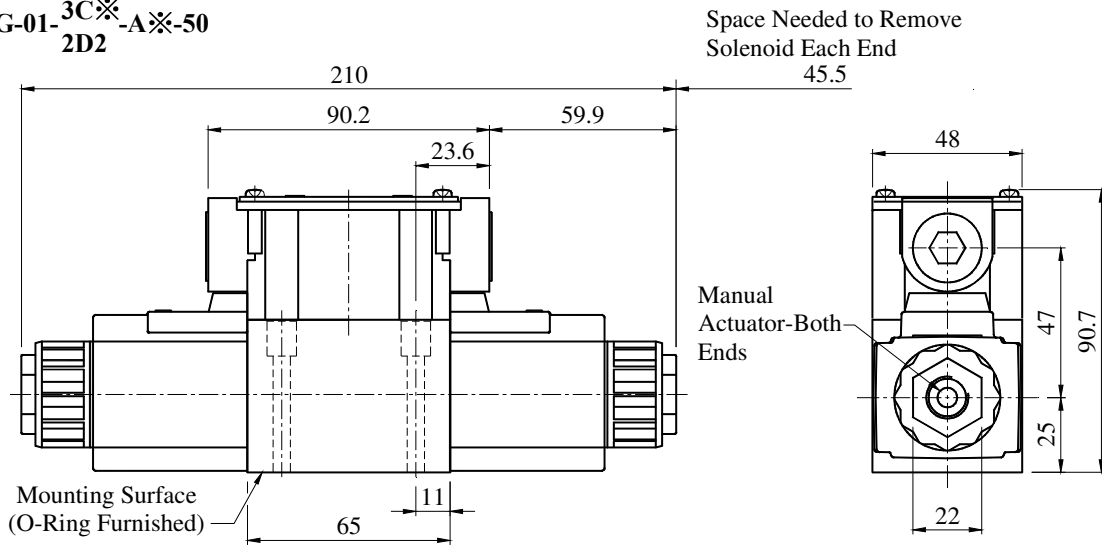

- **Single Solenoid: Spring Offset**

- **DSG-01-2B<sup>※</sup>-A<sup>※</sup>-50**

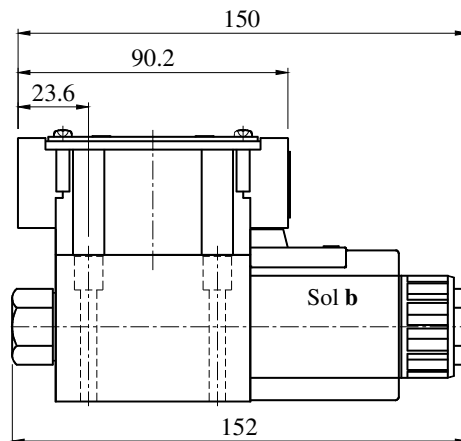

For other dimensions, refer to models with Double Solenoid.  
Alternate models using solenoid "a" are also available.

**Models With DC & R Solenoid**

- Spring Centred, No-Spring Detented & Spring Offset
- **3C<sup>※</sup>**
- **(S)-DSG-01-2D2 -A<sup>※</sup>-50**  
**2B<sup>※</sup>**

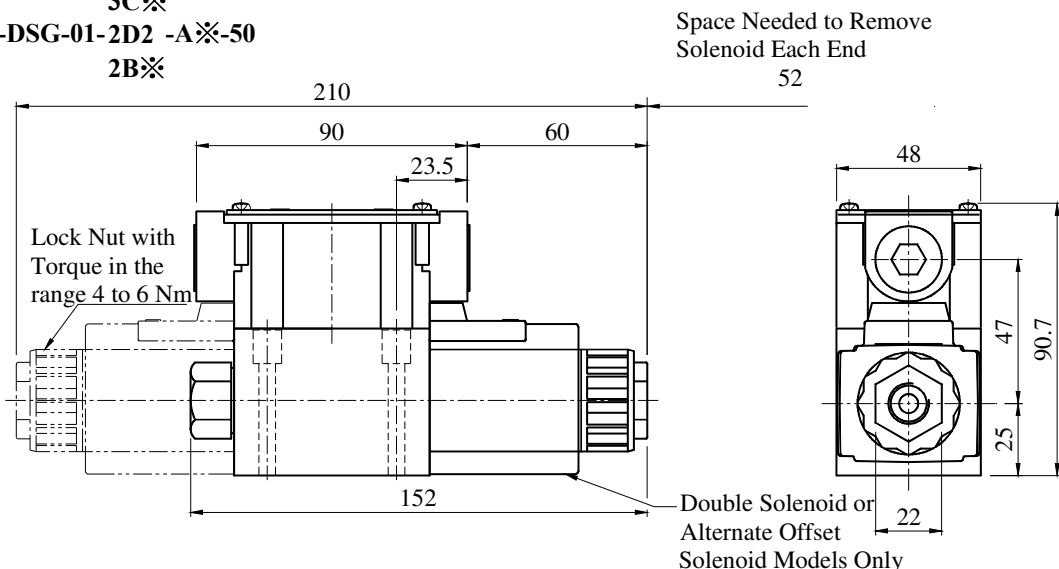

PLUG-IN CONNECTOR TYPE (N)  
PLUG-IN CONNECTOR WITH INDICATOR LIGHT (N1)

**Models With AC Solenoid : DSG-01-\*\*\*-A\*-N-50**

**DIMENSIONS IN MILLIMETRES**

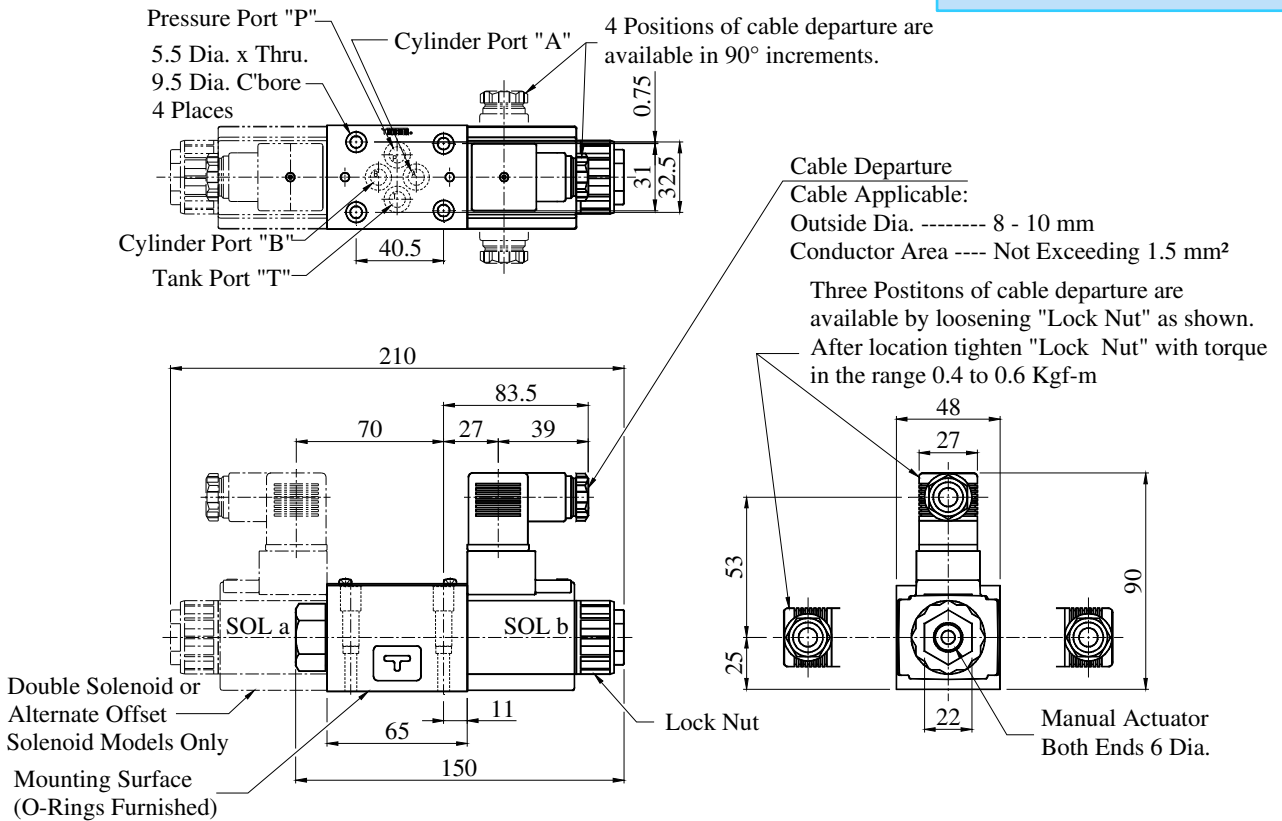

**Models With DC Solenoid : DSG-01-\*\*\*-D\*-N-50**

The connector can be moved to various positions by loosening the "Lock nut". After location tighten "Lock Nut" with torque in the range 0.4 to 0.6 Kgf-m

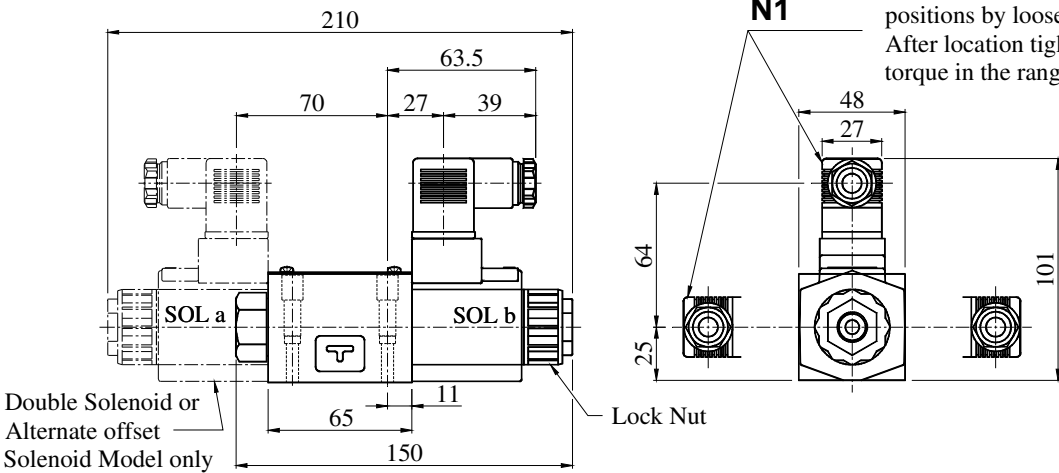

**Models With R Solenoid : DSG-01-\*\*\*-R\*-N-50**

Three Positions of cable departure are available by loosening "Lock Nut" as shown. After location, tighten "Lock Nut" with torque in the range 0.4 to 0.6 Kgf-m

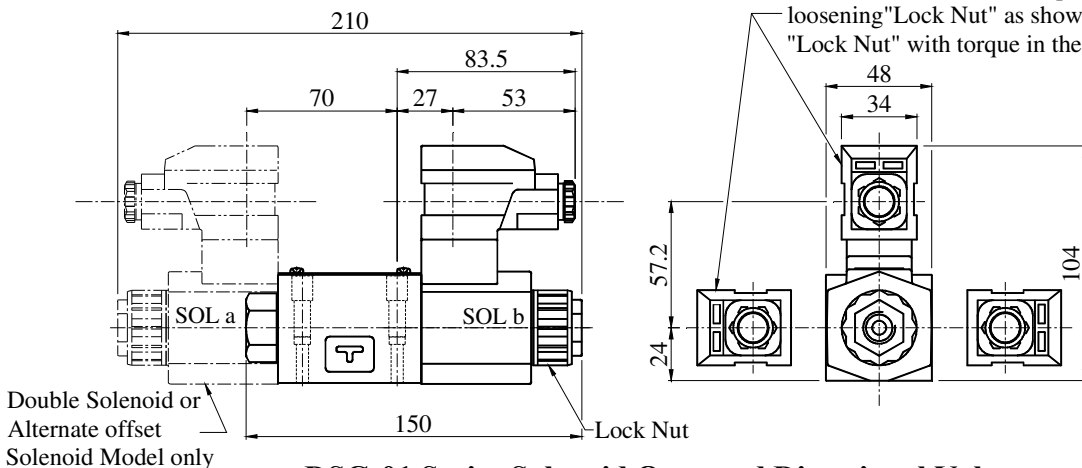

**DSG-01 Series Solenoid Operated Directional Valves**

**Sub Plates**

**DIMENSIONS IN MILLIMETRES**

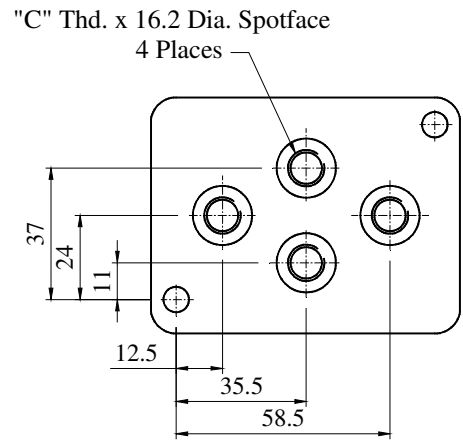
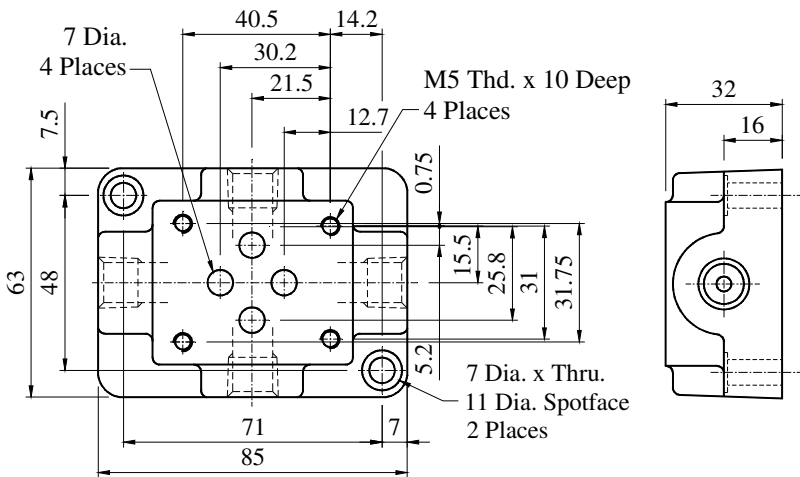

Sub-Plate Model Numbers	"C" BSP.F
DSGM-01-3080	1/8
DSGM-01X-3080	1/4
DSGM-01Y-3080	3/8

Sub-Plates are available specify sub-plate model from the table above. When sub-plates are not used, the mounting surface should have a good machined finish.

**Spare Parts List**

**List of Seals**

Model Numbers	O-Ring Details For Seal Kit	Qty.		
		3C※	2D※	2B※
DSG-01-※※※-※※-50	SO-NB-P9	4	4	4
	SO-NB-P18	2	2	1
	SO-NA-P4	4	4	2
DSG-01-※※※-※※- <b>N</b> -50	SO-NB-P9	4	4	4
	SO-NB-P18	2	2	1

Note: When ordering the seals, please specify the seal kit number as shown above.

**List of Seal kits**

Valve Model Numbers	Seal Kit Numbers
DSG-01-※※※-※※-50	KS-DSG-01-50
DSG-01-※※※-※※- <b>N</b> -50	KS-DSG-01- <b>N</b> -50