



RADIAL PISTON PUMPS

Model : 1RC****

Ref. No. D 04892
Release 11 / 2020

ENGINEERING - 1 of 3

A Polyhydron Group Company

Description

Model **1RC****** are small, low weight, rugged radial piston pumps with 2, 3, 5 or 7 pumping elements. These pumps are valve controlled and have no restriction on direction of rotation. These pumps can be submerged in oil or externally mounted above oil level.

Pumps with model code **1RCE***** have extension shaft for through drive and are available with extension bracket assembly for coupling a pump having standard flange as per ISO 3019/1. Refer data sheet no. D 09090 for Extension Bracket details.

These are available with 28 displacements and 7 pressure ratings. The pumps give fixed output per revolution of the shaft.

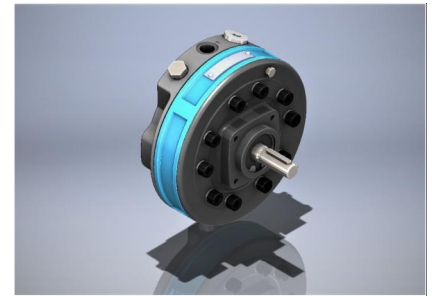

Section

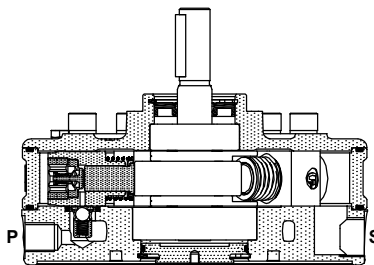

Model : 1RC***

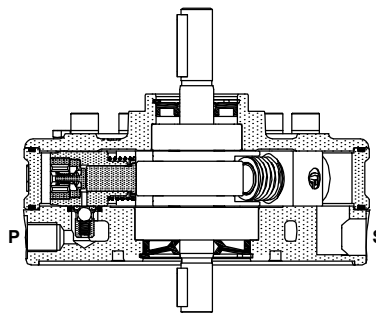

Model : 1RCE***

Hydraulic symbol

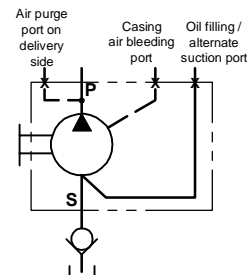

Model : 1RC***

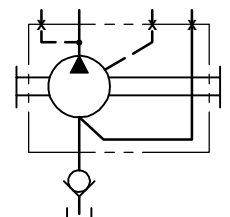

Model : 1RCE***

Technical specifications

Designation	:	1RC is a basic radial piston pump with casing. 1RCE is a radial piston pump with casing and extension shaft.								
Design	:	Radial piston, valve controlled.								
No. of elements	:	2, 3, 5 or 7.								
Mounting interface	:	Factory standard, Face mounting with Air purge port at highest level. Suction Foot Valve recommended refer data sheet no. D 12400.								
Direction of rotation	:	1RC - No restriction on direction of rotation. 1RCE - Depends upon the direction rotation of pump attached.								
Connection	:	Suction port (S)	- G1/2 female.							
		Delivery (P)	- G3/8 female.							
Speed range	:	300 to 2000 r/min.								
Max. Suction Head	:	At no time allow the oil level in the tank to fall 500 mm below the axis of the pump, when the pump is mounted horizontally, or 500 mm below the mounting face of the pump, when the pump is mounted vertically (case filling recommended).								
Flow and Pressure	:	Refer Table no. 1								
Torque limitations	:	Input drive shaft	- 75 Nm							
		Extension shaft	- 53 Nm							
Hydraulic medium	:	Mineral oil.								
Temperature range	:	-20°C to + 80°C.								
Viscosity range	:	10 cSt to 100 cSt.								
Fluid cleanliness required	:	ISO 4406 20/18/15 or better.								
Mass	:	Model :	1RC2	1RCE2	1RC3	1RCE3	1RC5	1RCE5	1RC7	1RCE7
		Kg :	9.17	9.25	9.67	9.78	10.38	10.52	11.15	11.2

polyhydron pvt. ltd.

78-80, Machhe Industrial Estate,
Machhe, Belgaum - 590 014. INDIA.

Phone : +91-(0)831- 2411001
Fax : +91-(0)831- 2411002
E-mail : polyhydron@gmail.com
Website : www.polyhydron.com



Unit dimensions

Dimensions in mm.

Pump without extension shaft

Model - 1RC***

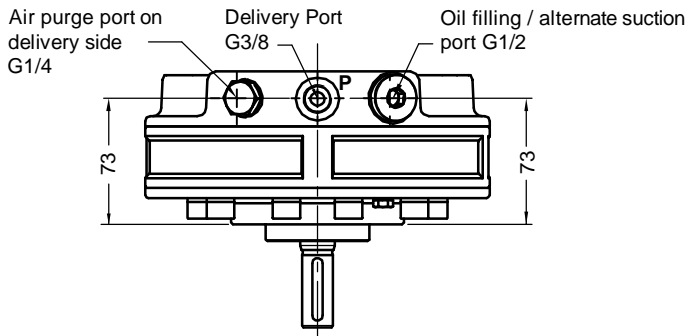
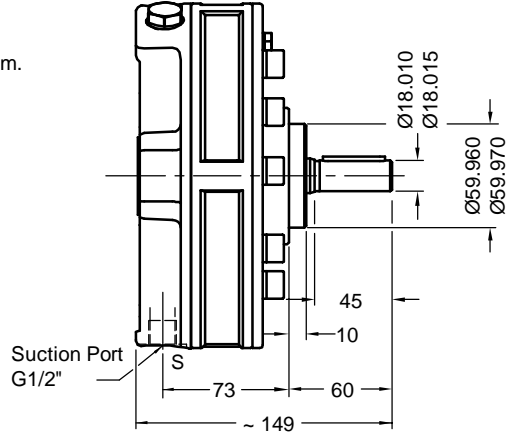
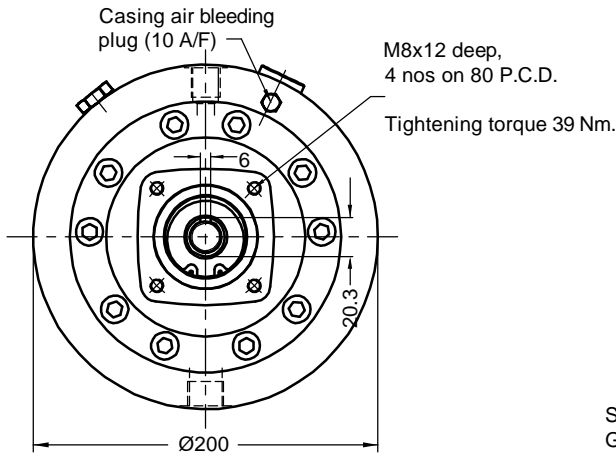
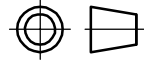

Pump with extension shaft

Model - 1RCE***

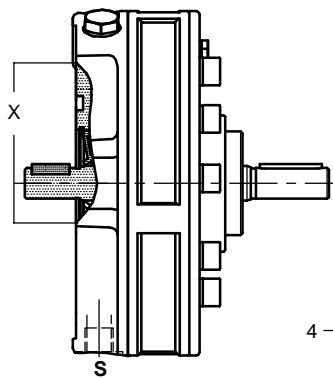
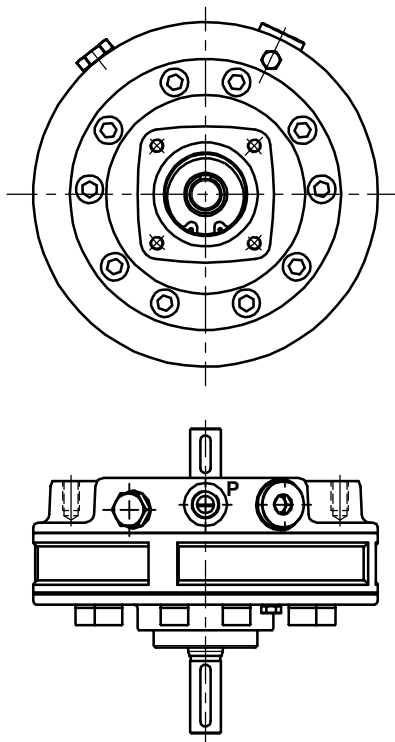

Extension bracket mounting
M10 x 17 deep holes, 2 nos.
Tightening torque 77 Nm.

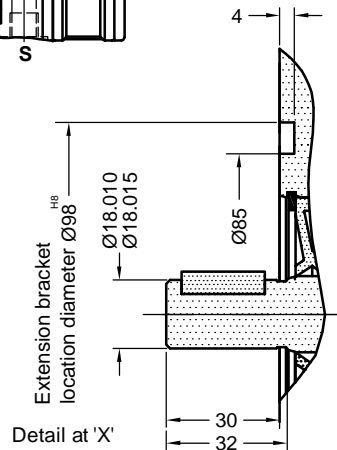
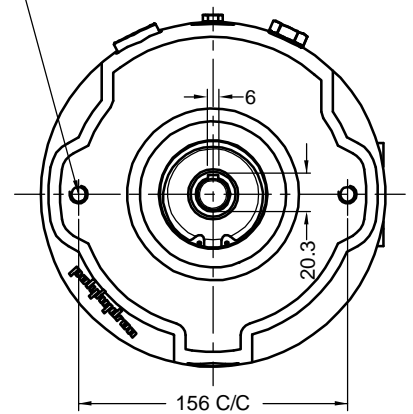



Performance Table no. 1

No. of pumping elements	Element type	Geometrical displacement in cm ³ /r	Pump output in l/min At 1450 r/min	Maximum Operating pressure in bar	Pressure in bar													
					50	100	150	200	250	300	350	400	450	500	550	600	650	700
					Power required to drive the pump in kW													
2	Z	0.45	0.6	700	0.06	0.13	0.19	0.26	0.32	0.39	0.45	0.51	0.58	0.64	0.71	0.77	0.84	0.90
3		0.69	0.9		0.10	0.19	0.29	0.39	0.48	0.58	0.68	0.77	0.87	0.96	1.06	1.16	1.25	1.35
5		1.15	1.5		0.16	0.32	0.48	0.64	0.80	0.96	1.13	1.29	1.45	1.61	1.77	1.93	2.09	2.25
7		1.61	2.2		0.23	0.45	0.68	0.90	1.13	1.35	1.58	1.80	2.03	2.25	2.48	2.70	2.93	3.15
2	A	0.80	1.1	550	0.11	0.23	0.34	0.46	0.57	0.69	0.80	0.91	1.03	1.14	1.26			
3		1.20	1.6		0.17	0.34	0.51	0.69	0.86	1.03	1.20	1.37	1.54	1.71	1.89			
5		2.00	2.7		0.29	0.57	0.86	1.14	1.43	1.71	2.00	2.29	2.57	2.86	3.14			
7		2.80	3.8		0.40	0.80	1.20	1.60	2.00	2.40	2.80	3.20	3.60	4.00	4.40			
2	B	1.25	1.7	450	0.18	0.36	0.54	0.71	0.89	1.07	1.25	1.43	1.61					
3		1.89	2.6		0.27	0.54	0.80	1.07	1.34	1.61	1.88	2.14	2.41					
5		3.15	4.3		0.45	0.89	1.34	1.79	2.23	2.68	3.13	3.57	4.02					
7		4.41	6.0		0.63	1.25	1.88	2.50	3.13	3.75	4.38	5.00	5.63					
2	C	1.80	2.5	350	0.26	0.51	0.77	1.03	1.29	1.54	1.80							
3		2.70	3.7		0.39	0.77	1.16	1.54	1.93	2.32	2.70							
5		4.50	6.2		0.64	1.29	1.93	2.57	3.22	3.86	4.50							
7		6.30	8.6		0.90	1.80	2.70	3.60	4.50	5.40	6.30							
2	D	2.12	2.9	300	0.30	0.60	0.91	1.21	1.51	1.81								
3		3.18	4.3		0.45	0.91	1.36	1.81	2.26	2.72								
5		5.30	7.2		0.75	1.51	2.26	3.02	3.77	4.53								
7		7.42	10.1		1.06	2.11	3.17	4.23	5.28	6.34								
2	E	2.46	3.4	250	0.35	0.70	1.05	1.40	1.75									
3		3.69	5.0		0.53	1.05	1.58	2.10	2.63									
5		6.15	8.4		0.88	1.75	2.63	3.50	4.38									
7		8.61	11.7		1.23	2.45	3.68	4.90	6.13									
2	F	2.82	3.9	200	0.40	0.80	1.21	1.61										
3		4.23	5.8		0.60	1.21	1.81	2.41										
5		7.05	9.6		1.00	2.01	3.01	4.02										
7		9.87	13.5		1.41	2.81	4.22	5.63										

1kW = 1.34 hp

Ordering code

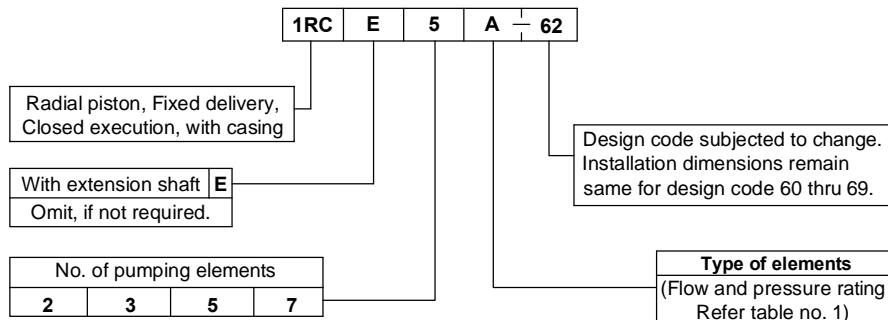

Note :For Bell housing refer Data sheet no. D 09035 and For extension bracket refer Data sheet no. D 09090.
For commissioning of pump refer datasheet no. D 11200 L.

All rights reserved.
Subject to change without notice.
Due to continuous improvements in the design of the product, the actual product supplied may look different than shown above, but will have same mounting dimensions.
For critical applications, please ask for certified installation drawing.

All rights reserved.
Subject to revision